

# SOLUTIONS FOR CONTROL ROOMS



**ZPAS**  
GROUP

solutions for connections



solutions for connections

ZPAS

GROUP

## ZPAS Milestones – 47 years of experience

2019 – new investments in machinery

2018 – ZPAS celebrates its 45th birthday with all the employees

2016 – opening of an electrical assembly plant with an area of 9 000 m<sup>2</sup>  
in Nowa Ruda – Drogosław at Piłsudskiego Street

2007 – opening of a production plant with an area of 3 500 m<sup>2</sup>  
in Nowa Ruda – Drogosław at Górnicza Street

2007 – opening of a 10 000 m<sup>2</sup> serial production plant in Nowa Ruda – Słupiec

2003 – the Przygórze plant expanded with new production halls and automatic powder coating plant

1991 – transformation of the experimental plant into the Network Automation Manufacturing Plant (ZPAS) and privatization of the company – joint stock company established

1973 – the former steelworks “Barbara” and buildings of the Przygórze mine “Bolesław”,  
decommissioned in 1971, become the seat for the Experimental Department of the Wrocław  
Power Systems Institute

**We are an innovative company, offering our customers comprehensive solutions for data communication, power engineering and automation.**

**Our products are used by companies such as General Electric, Siemens, ABB, Dell, Porsche, Homag and many others world leaders. Recently, we have launched a state-of-the-art electrical production plant. The area of 9 000 m<sup>2</sup> is a place for specialized production related to electrical prefabrication of cabinets and production of AHP heat pumps which is a world-wide unique cooling solution for outdoor cabinets.**

**Dynamic growth of the company also means taking care of the local community and the environment. ZPAS has always supported institutions of culture, sport and social development.**

***Piotr Baranowski***  
*President of the Board  
of ZPAS S.A.*

**”** People power – the real engine of any business.  
Good people are not just crucial to a business.  
They are the business themselves!

*Richard Branson*



See the video:  
[zpas.pl/qr/f16](https://zpas.pl/qr/f16)

# ZPAS PRODUCTION PLANTS



**Przygórze**  
ZPAS S.A. Management Board Office, administration and design production plant



**Nowa Ruda – Drogosław, Piłsudskiego Street**  
Manufacturing plant – electrical assembly



**Nowa Ruda – Drogosław, Górnicza Street**  
Outdoor Enclosures Production Plant



**Nowa Ruda – Słupiec, Spacerowa Street**  
Serial production plant and warehouse for finished products





For standard indoor products, the manufacturer provides a 5-year guarantee for mechanical components.

Electrical and electronic components, as well as woodwork finishes (desktops and covers) are covered by a 2-year guarantee, provided that they are used as intended and serviced in accordance with the manufacturer's instructions.

For outdoor and custom-made products, the guarantee is determined individually.

**QUALITY AND ENVIRONMENTAL MANAGEMENT SYSTEM**



SCOPE OF OFFER

**Comprehensive construction of control rooms**

Taking into account the experience gained so far from various industries, ZPAS meets the challenges faced by our customers, implementing a comprehensive range of control centres – control rooms, both for power generators and suppliers, as well as for chemical, gas, water, coking plants, coal mines, railway interlocking stations and other industrial and economic sectors.

Comprehensive control room implementation may include:

- construction works (architecture and interior design),
- sanitary installations – air-conditioning (including precision air-conditioning), ventilation and heating,
- visualisation systems – matrix boards, graphic walls (videoscreens),
- dispatch desks including electrical and teletechnical equipment,
- primary and backed-up power supply systems,
- general, emergency and evacuation lighting systems,
- teletechnical system (access control, LAN, CCTV, fibre optic network),
- structured cabling systems,
- fire protection systems,
- server room equipment.

ZPAS is able to build all the components of a modern dispatch centre – from concept (proposals of solutions including visualizations), through basic and detailed designs (including all approvals and permits) up to implementation.



SAMPLE REALISED PROJECTS

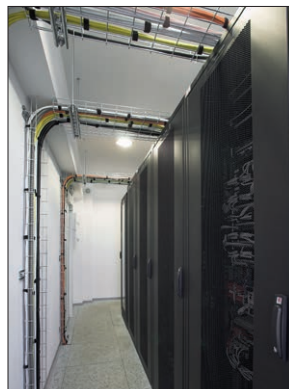
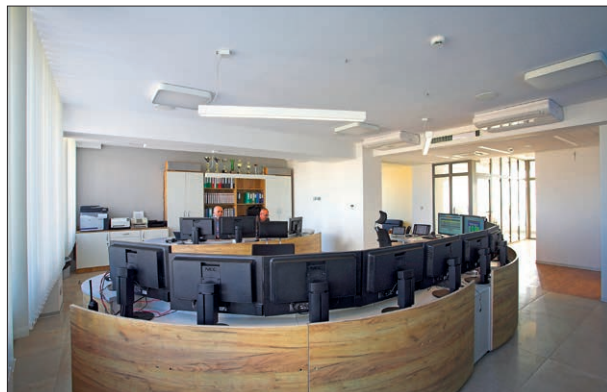

SAMPLE REALISED PROJECTS

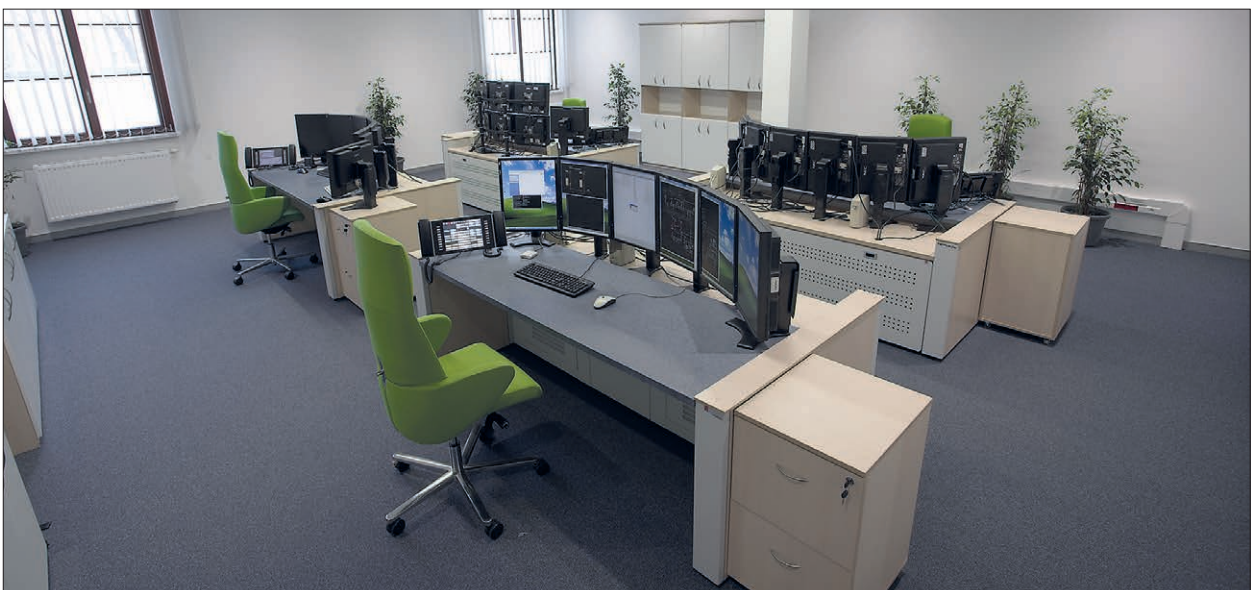

SAMPLE REALISED PROJECTS



SAMPLE REALISED PROJECTS

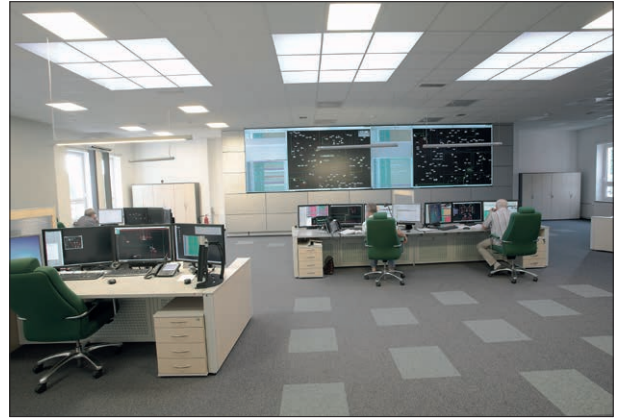

SAMPLE REALISED PROJECTS



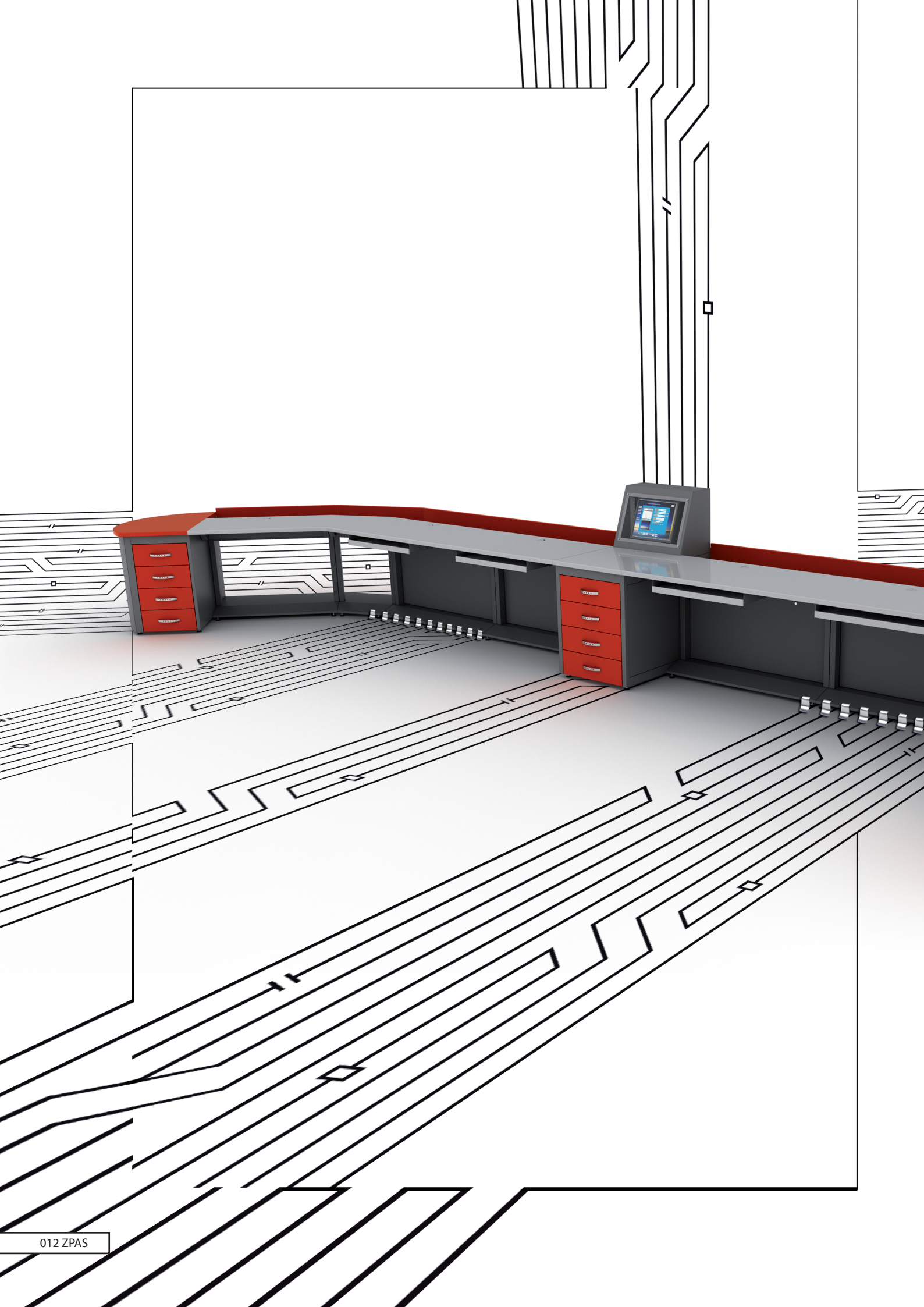

# DISPATCH WORKSTATIONS

- General description of desks ..... 14
- PDM Classic ..... 16
- PDM Comfort ..... 24
- PDM Control ..... 32
- Sample customised projects ..... 38
- Accessories ..... 39

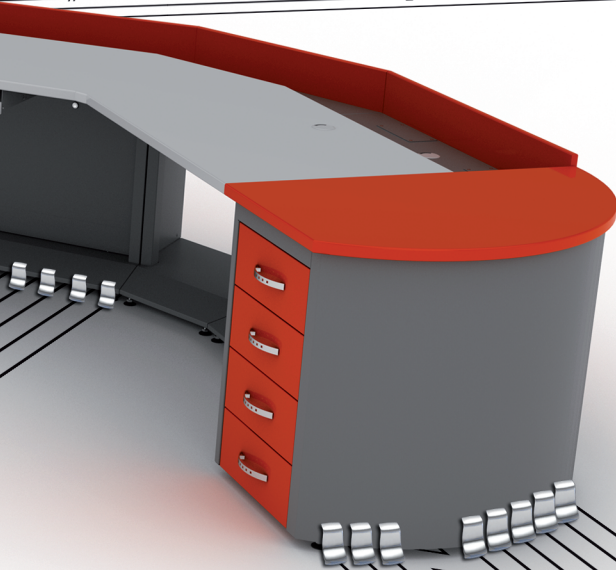

## GENERAL DESCRIPTION OF DESKS

ZPAS is a very experienced manufacturer of modular dispatch desks which are mainly used in control rooms and dispatch rooms of power plants, CHP plants, chemical plants, gas plants, water supply plants, coking plants, coal and lignite mines, as well as in other branches of industry. They are also used in emergency services dispatch rooms and railway interlocking stations.

The desks can hold control and measurement apparatus, computer equipment and devices used for process visualisation.

The offer includes universal modular desks and customized desks according to customer designs or documentation prepared by ZPAS Design Department.

The desks are often part of a complex order. Having abundant experience in industrial design, ergonomics and interior design, ZPAS is able to build complex dispatch centres, including desks and graphic walls, from designing and preparing visualization through implementation and installation on premises.

We present room arrangements with complete interior equipment. Thanks to the visualization, we can simulate how the room will look like, choose appropriate colours for walls, floors and ceilings to match the suggested colours of the desks. These simulations allow you to choose the best solution at the design stage, so that you can be satisfied with the result.

The delivery of each desk can include complete electrical equipment together with an on-site connection.



## GENERAL DESCRIPTION OF DESKS

For dispatch desks, ZPAS manufactures structures that match the shape and functionality of a specific facility. Dispatch desks, which also serve as operator's desks, consist of a metal section that forms the structural base of the desk, as well as the desktop and optional extensions.

Since desks are used 24/7, they are made of the highest quality materials to deliver high durability and pleasant appearance. A wide range of materials, from wood-like panels to synthetic plastics, is used for desktops depending on the needs and the required standard. For simple structures that require inexpensive technologies we use laminated boards or MDF panels with a finishing of your choice. For greater flexibility, you can choose mineral and acrylic materials such as Staron or Corian.

The desktops can hold cassettes with safety buttons and mosaic mimic panels. The tops can be fitted with extensions of any shape and dimensions. This allows easy installation of monitors, buttons, meters, displays or other devices.

Metal parts of the desks can be painted or made of stainless steel without any additional surface finish. For painting, epoxy-polyester powder paints with the so-called thick structure in colours from the RAL catalogue are used.



# PDM Classic DISPATCH DESKS

APPLICATIONS • ROOM ARRANGEMENTS WITH COMPLETE INTERIOR EQUIPMENT

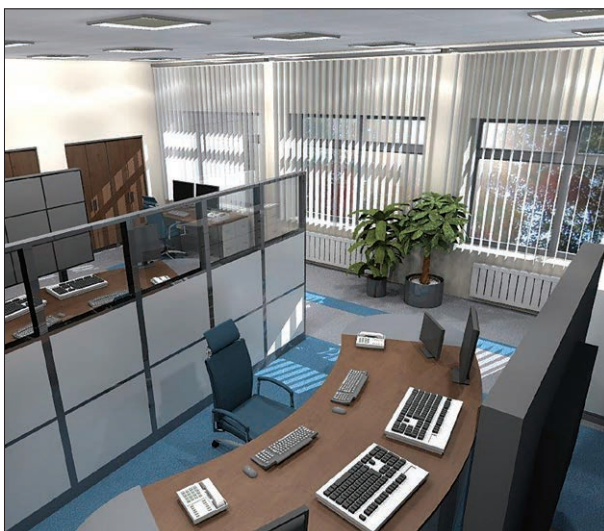

DISPATCH DESKS **PDM Classic**

## CHARACTERISTICS

**PDM Classic**

Modular dispatch desks allows you to create combinations of any size and configuration, depending on your needs.

Basic features:

- four standard components: PC module, central module, side module, 15° wedge, side wedge
- desktops made of MDF board covered with laminate or mineral-acrylic materials
- freedom of configuration – create simple, curved or bent combinations
- freedom of colours – both for metal part of the desktop and the woodwork
- modular design so that the desk can be adapted to any room
- 19" standard or other equipment can be installed
- easy access to installed equipment
- easy layout of wiring
- you can choose where the desktop will have openings for buttons and cassettes, and you can have extensions
- possibility of using forced or gravitational ventilation
- comply with the health and safety regulations
- CE-certificated

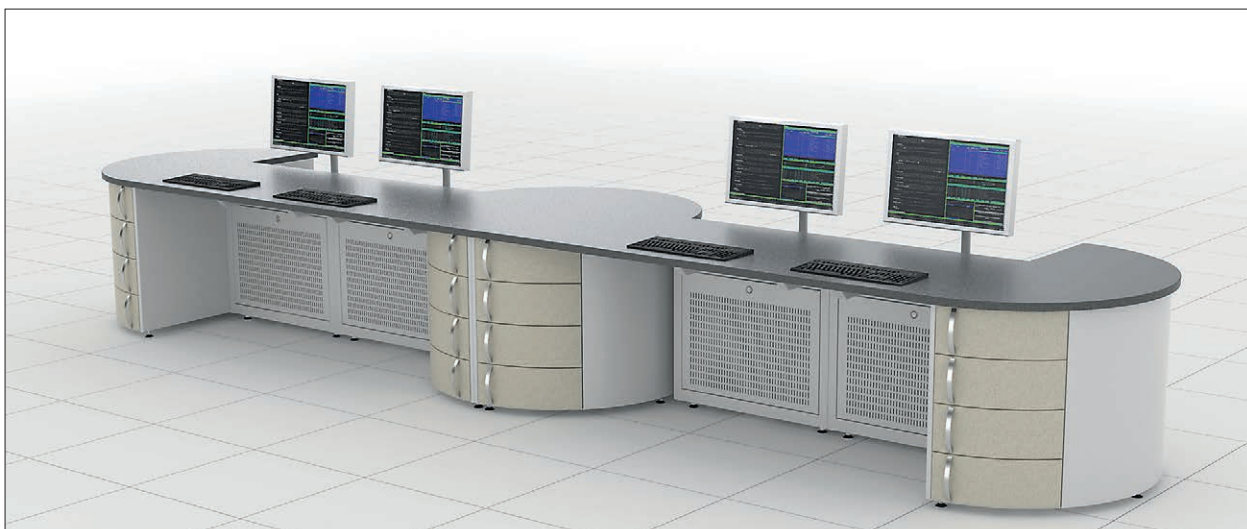

# PDM Classic

DISPATCH DESKS

## COMPONENTS



## PC module

A two-tier 19" cabinet designed for installing the central unit of the system or other types of electronic devices. The upper part of the cabinet is used as a support for the operating desktop, while the lower (rear) part is designed for placing monitors. Two PC modules are designed for one workstation.



## Central module with 8 drawers

Central cylinder-shaped element which makes it possible to arrange sets at any desired angle.

It can be connected to:

- the PC module,
- the shield joining the central module with the PC module.



## Side module with 4 drawers

Side half-cylinder-shaped element for closing the set.

It can be connected to:

- the PC module,
- the shield joining the side module with the PC module,
- the other half of the cylinder (central module).



## 15° wedge

The wedge enables bending sets by 15°. If more than one wedge is used, then the bending angle can be increased.

It can be connected to:

- the PC module.



## Side wedge

An end element (without drawers).

It can be connected to:

- the PC module.

DISPATCH DESKS **PDM Classic**

COMPONENTS

**Rear shield**

A shield for covering the rear space between the cylinder-shaped central module and the PC module.

It can be connected to:

- the PC module,
- the cylinder-shaped central module.

**Desktops**

Desktops, sides, tops and other elements of dispatch desks can be made of modern synthetic materials - depending on customers' needs and the required standard. Given the fact that they are used round-the-clock, consoles must be made of high-quality materials ensuring long durability and visual attractiveness.

Desktops of the proposed modular dispatch desk are made of the following materials:

- MDF board, laminated, with increased resistance to abrasion, with edges protected by PVC strip matching the colour of the desktop. The working desktop is approx. 30 mm thick whereas the monitor desktop is approx. 21 mm thick.
- Modern synthetic materials, for example Corian, Staron.



# PDM Classic DISPATCH DESKS

DIMENSIONS • SAMPLE CONFIGURATIONS

An appropriate configuration of the typical components described above allows to create a virtually unlimited number of operator workstations.

## STRAIGHT-LINE DOUBLE-STATION DESK

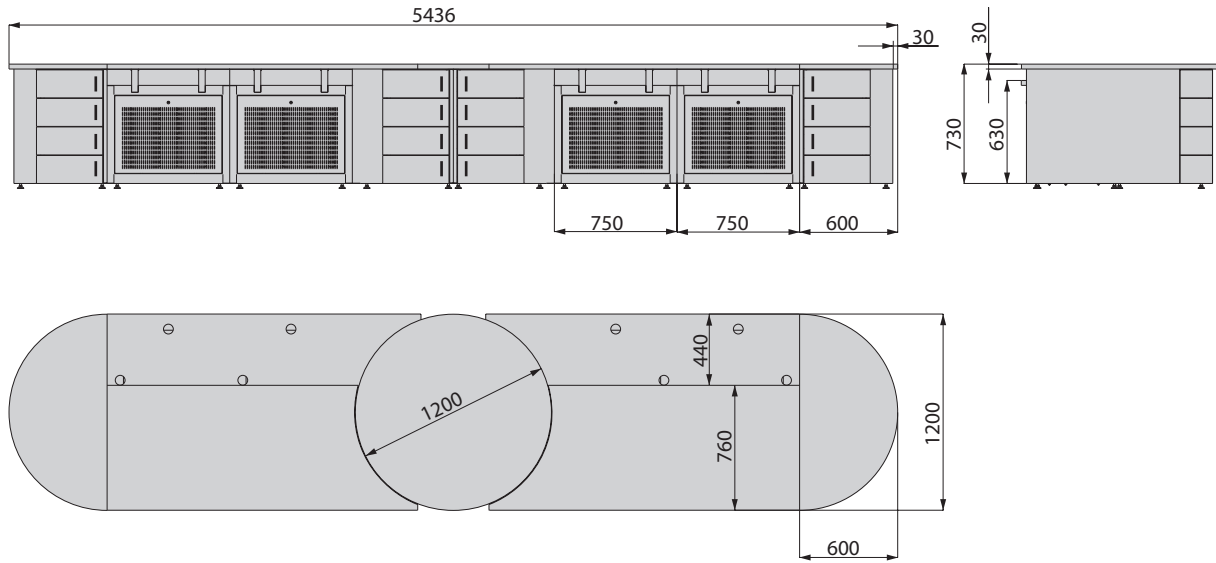

## SINGLE-STATION DESK

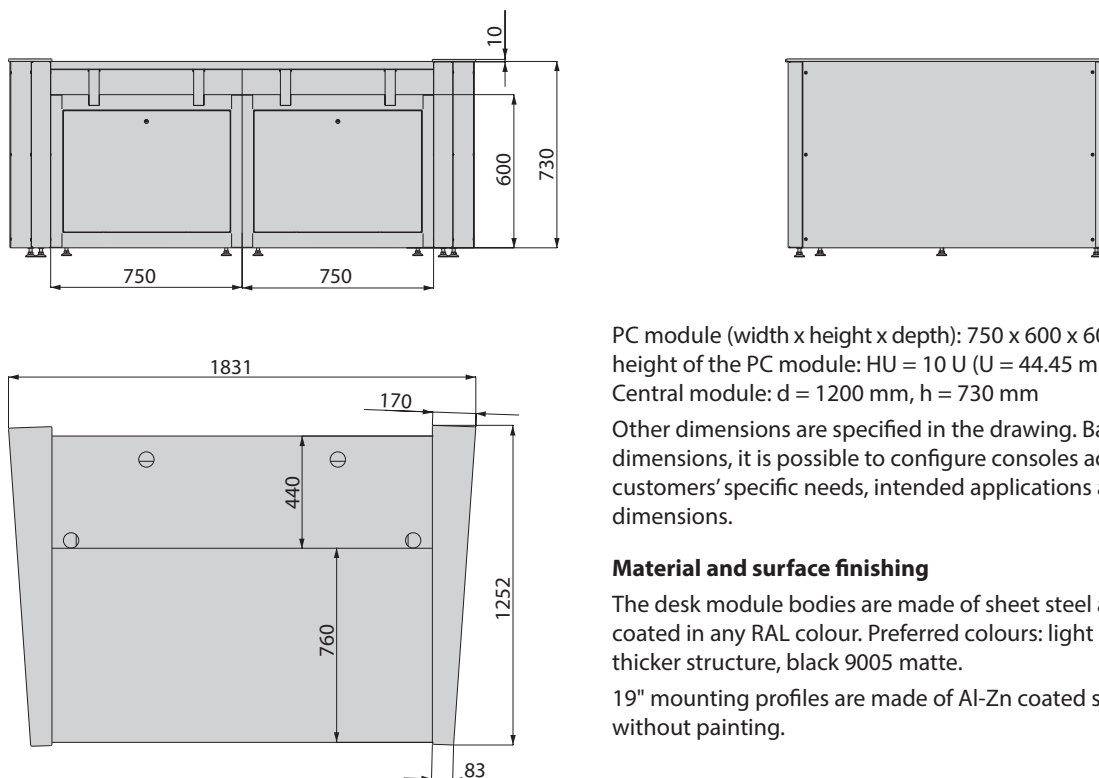

PC module (width x height x depth): 750 x 600 x 600 mm; useful height of the PC module: HU = 10 U (U = 44.45 mm)  
Central module: d = 1200 mm, h = 730 mm

Other dimensions are specified in the drawing. Based on overall dimensions, it is possible to configure consoles according to customers' specific needs, intended applications and room dimensions.

### Material and surface finishing

The desk module bodies are made of sheet steel and powder-coated in any RAL colour. Preferred colours: light grey 7035 with thicker structure, black 9005 matte.

19" mounting profiles are made of Al-Zn coated sheet steel without painting.

DISPATCH DESKS **PDM Classic**

DIMENSIONS • SAMPLE CONFIGURATIONS

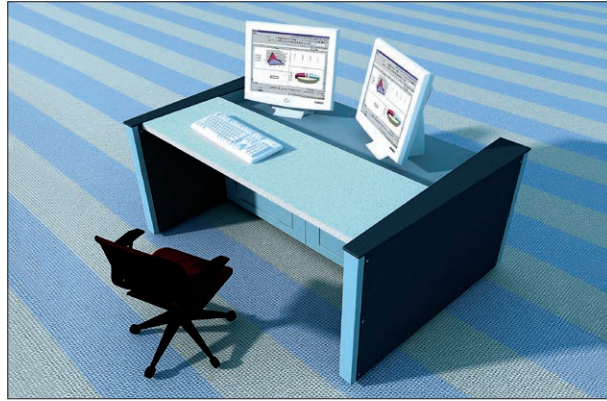
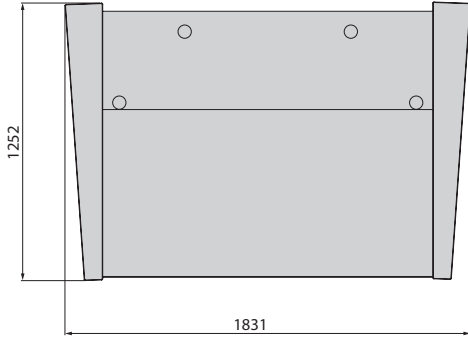

Single-station desk

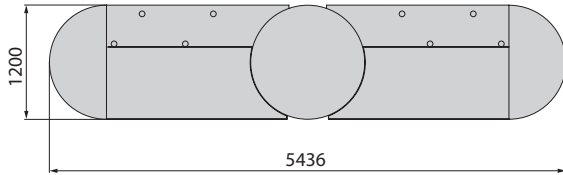

Straight-line double-station desk

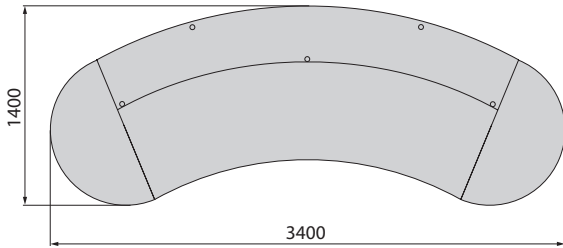

Arch-shaped single-station desk

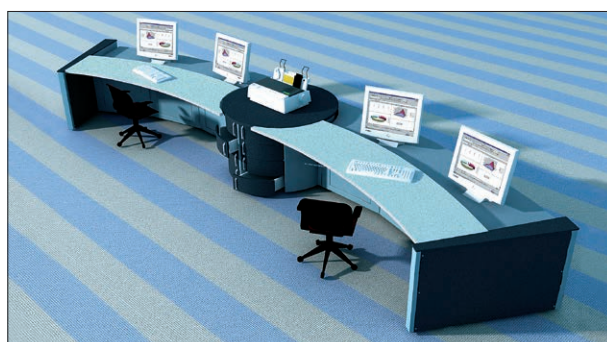
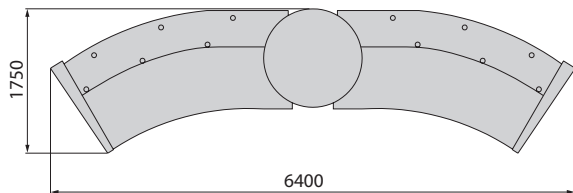

"Broken-line" double-station desk

# PDM Classic DISPATCH DESKS

SAMPLE IMPLEMENTATIONS • COMPLETED PROJECTS

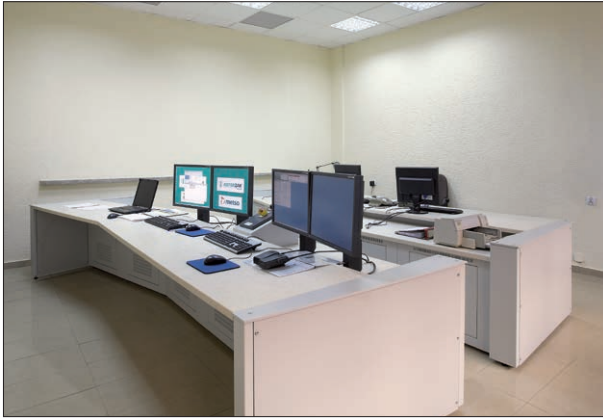

DISPATCH DESKS **PDM Classic**

SAMPLE IMPLEMENTATIONS • COMPLETED PROJECTS



# PDM ComFort DISPATCH DESKS

APPLICATIONS • ROOM ARRANGEMENTS WITH COMPLETE INTERIOR EQUIPMENT

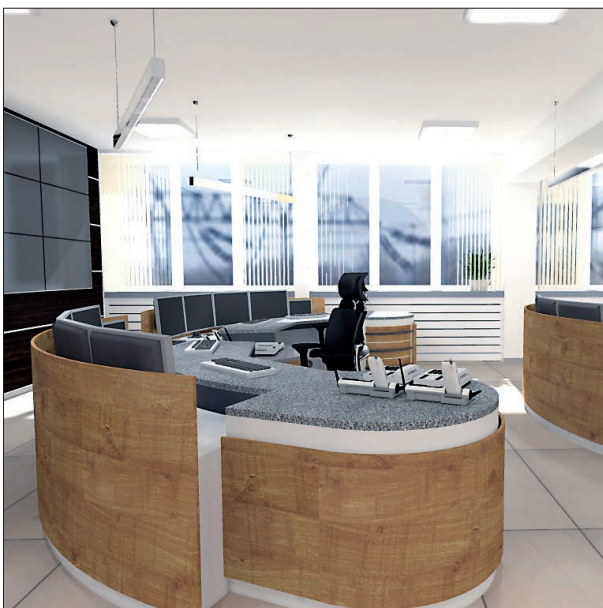

DISPATCH DESKS **PDM Comfort**

## CHARACTERISTICS

**PDM Comfort**

Modular dispatch desks with sleek appearance allows you to create combinations of any size and configuration, depending on your needs.

Unlike the PDM Classic desks, these have richer finishing options such as furniture covers in extreme modules and at back of the desk.

## Basic features:

- four standard components: PC module (simple or wedge module), central module, side module
- desktops made of MDF board covered with laminate or mineral-acrylic materials
- freedom of configuration – create simple, curved or bent combinations
- freedom of colours – both for metal part of the desk and the woodwork
- modular design so that the desk can be adapted to any room
- 19" standard or other equipment can be installed
- easy access to installed equipment
- easy layout of wiring
- you can choose where the desktop will have openings for buttons and cassettes, and you can have extensions
- possibility of using forced or gravitational ventilation
- comply with the health and safety regulations
- CE-certificated

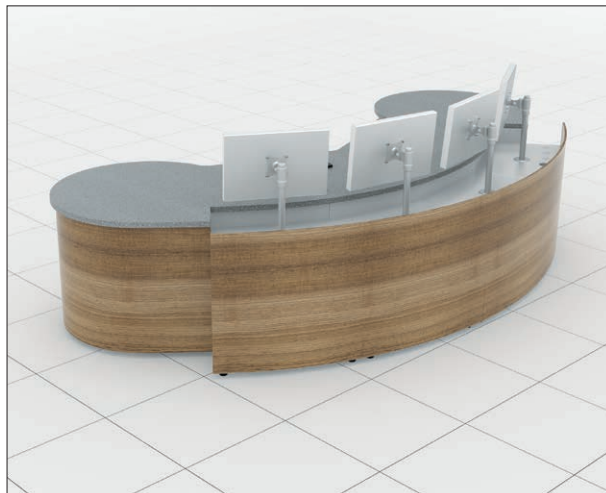

# PDM Comfort DISPATCH DESKS

## COMPONENTS



### PC module

A two-tier 19" cabinet designed for installing the central unit of the system or other types of electronic devices. The upper part of the cabinet is used as a support for the operating desktop, while the lower (rear) part is designed for placing monitors. The cabinet is set on the adjustable feet. Two PC modules are designed for one workstation.

Two versions available:

- a wedge-shaped PC module with 20° angle
- straight PC module



### Central module

Central wedge-shaped element with 20° angle. Equipped with eight drawers and adjustable feet. Can be combined with two PC modules.



### Side module

Side half-cylinder-shaped element for closing the set. Equipped with four drawers and adjustable feet. Can be combined with a PC module.

### Material and surface finishing

The desk module bodies are made of sheet steel and powder-coated in any RAL colour. Preferred colours: light grey 7035 with thicker structure, black 9005 matte.

19" mounting profiles are made of Al-Zn coated sheet steel without painting.

Drawer fronts made of laminated MDF (any colour from the pattern).

DISPATCH DESKS **PDM ComFort**

COMPONENTS

**Rear shield**

A panel covering the rear wall of two adjacent PC modules.

Material: MDF board, laminated, edges protected by PVC strip matching the colour of the cover, any colour from the chart.

**Desktops**

The modular design of the desk includes three types of tops:

- shared desktop for two adjacent PC modules,
- central module desktop,
- side module desktop.

Desktop materials to choose from:

- Chipboard laminated on both sides with edge protected by PVC strip matching the colour of the desktop.
- MDF board, laminated, with increased resistance to abrasion, with edges protected by PVC strip matching the colour of the desktop.
- Modern synthetic materials, for example Paracor/Plexicor, Corian, SSV.



# PDM Comfort DISPATCH DESKS

DIMENSIONS • SAMPLE CONFIGURATIONS

## SINGLE-STATION DESK • 4x PC wedge module, 2x side module

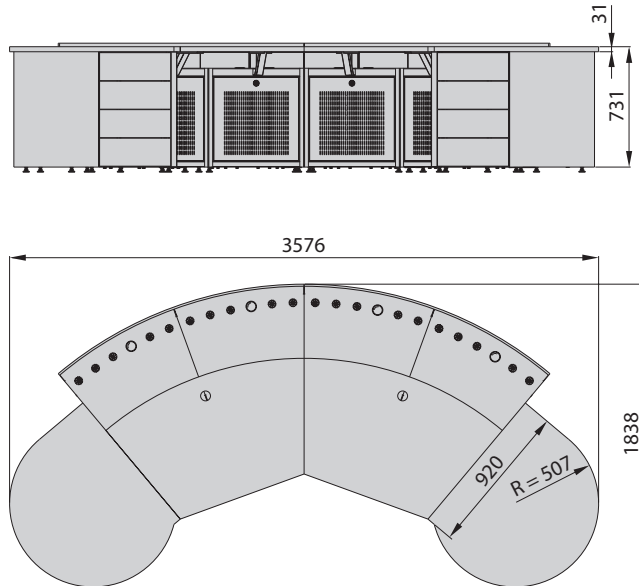

## DOUBLE-STATION DESK • 8x PC wedge module, 2x side module, 1x central module

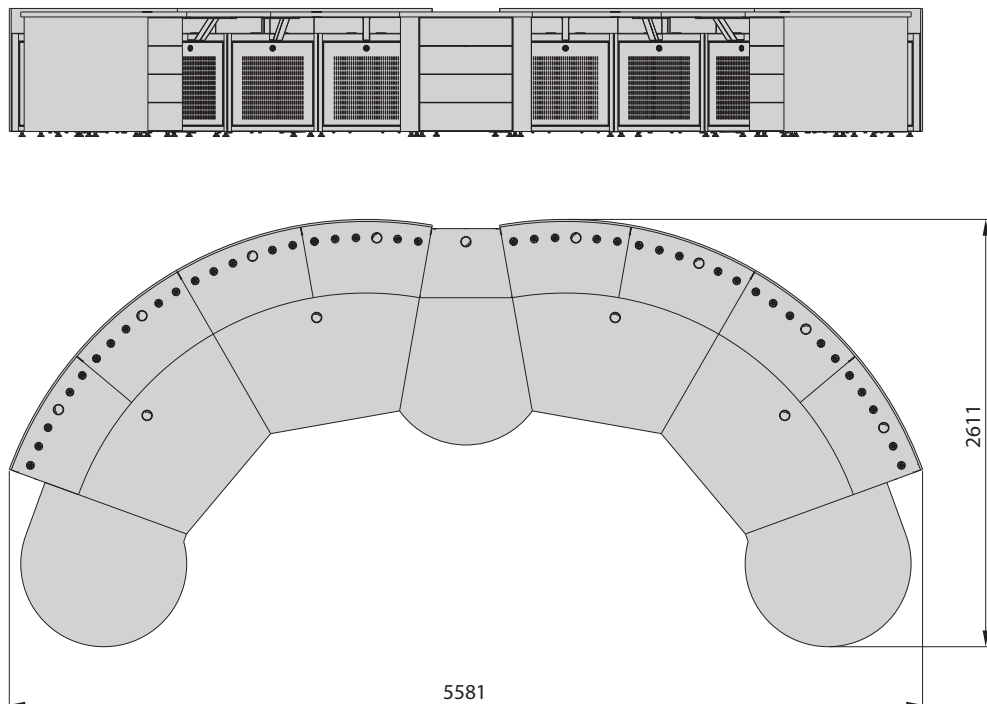

DISPATCH DESKS **PDM Comfort**

SAMPLE IMPLEMENTATIONS • COMPLETED PROJECTS



# PDM Comfort DISPATCH DESKS

DIMENSIONS • SAMPLE CONFIGURATIONS

**DOUBLE-STATION DESK • 6x PC wedge module, 3x PC straight module, 2x side module**

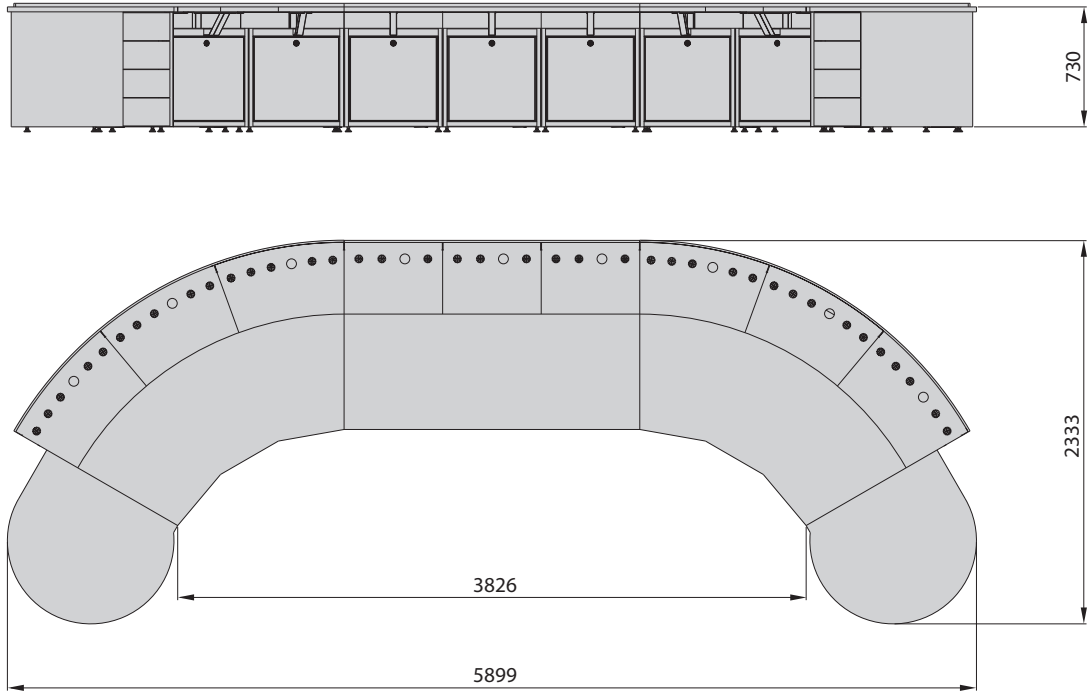

**DOUBLE-STATION DESK • 12x PC wedge module, 2x side module, 1x central module**

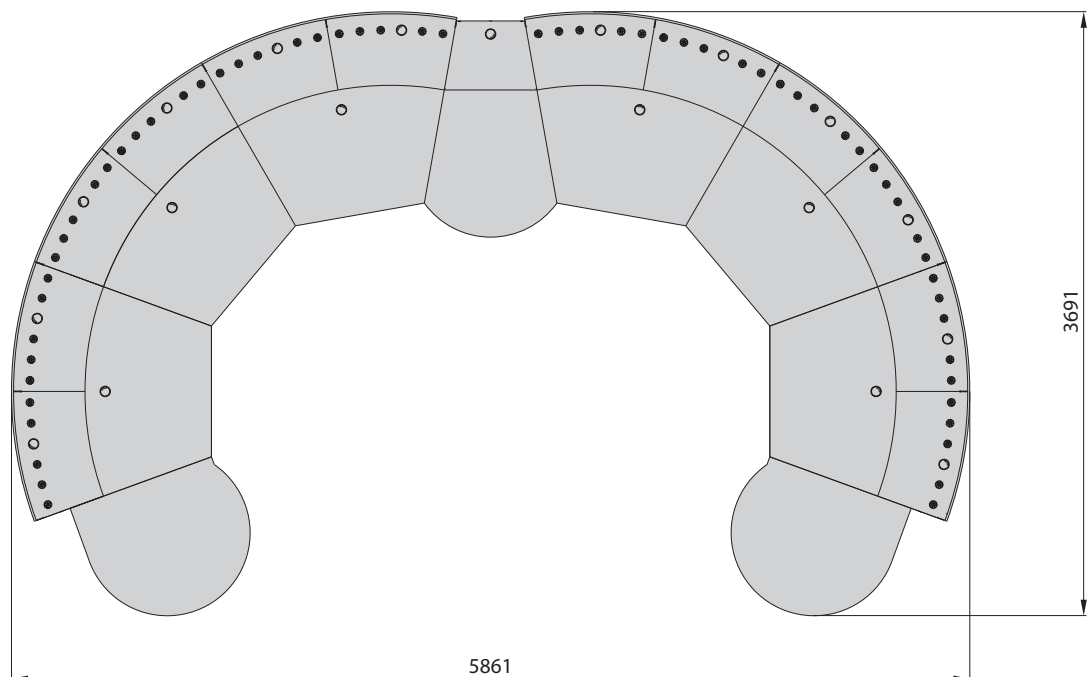

DISPATCH DESKS **PDM Comfort**

SAMPLE IMPLEMENTATIONS • COMPLETED PROJECTS



# PDM Control DISPATCH DESKS

APPLICATIONS • ROOM ARRANGEMENTS WITH COMPLETE INTERIOR EQUIPMENT



DISPATCH DESKS **PDM Control**

## CHARACTERISTICS

**PDM Control**

Simplified modular dispatch desks allows you to create combinations of any size and configuration, depending on your needs.

Unlike PDM Classic and Comfort desks in standard design, this one cannot hold 19" equipment, however, it can be easily combined with furniture cabinets.

## Basic features:

- three standard components: working module (simple or wedge module), central module, side module
- desktops made of MDF board covered with laminate or mineral-acrylic materials
- freedom of configuration – create simple, curved combinations
- freedom of colours – both for metal part of the desk and the woodwork
- modular design so that the desktop can be adapted to any room
- you can choose where the desktop will have openings for buttons and cassettes, and you can have extensions
- comply with the health and safety regulations
- CE-certificated



# PDM Control DISPATCH DESKS

## COMPONENTS



### Working module

Desk desktop base. The upper part serves as a support for the worktop, the lower part acts as a shelf for monitors. The module is set on adjustable feet. Two working modules are provided for one workstation.

The working module is available in two versions:

- wedge version (allows you to bend the desktop at an angle of approx. 8°),
- straight version.



### Central module

Central element in the shape of a cabinet.

Equipped with four drawers and adjustable feet.

Can be combined with two working modules.

### Material and surface finishing

Body and frames of desk modules are made of sheet steel and powder-coated in any RAL colour. Preferred colours: light grey 7035 with thicker structure, black 9005 matte.

Drawer fronts made of laminated MDF (any colour from the pattern).

DISPATCH DESKS **PDM Control**

COMPONENTS

**Side module**

Side half-cylinder-shaped element for closing the set.  
Equipped with four drawers and adjustable feet.  
Can be combined with the working module.

**Desktops and rear panel**

With the modular desk design, the following desktops and panels can be used:

- worktop,
- monitor shelf top (optional),
- working module panel,
- central module desktop,
- side module desktop.

Desktop materials to choose from:

- Chipboard laminated on both sides with edge protected by PVC strip matching the colour of the desktop.
- MDF board, laminated, with increased resistance to abrasion, with edges protected by PVC strip matching the colour of the desktop.
- Modern synthetic materials, for example Paracor/Plexicor, Corian, SSV.



# PDM Control DISPATCH DESKS

DIMENSIONS • SAMPLE CONFIGURATIONS

## STRAIGHT-LINE DOUBLE-STATION DESK • 3x working straight module, 2x side module

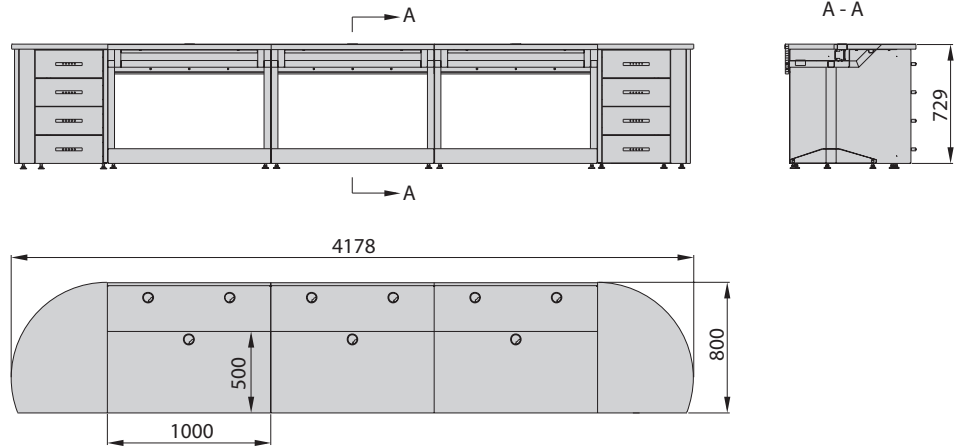

## ARCH-SHAPED THREE-STATION DESK • 8x working wedge module, 2x side module, 2x central module

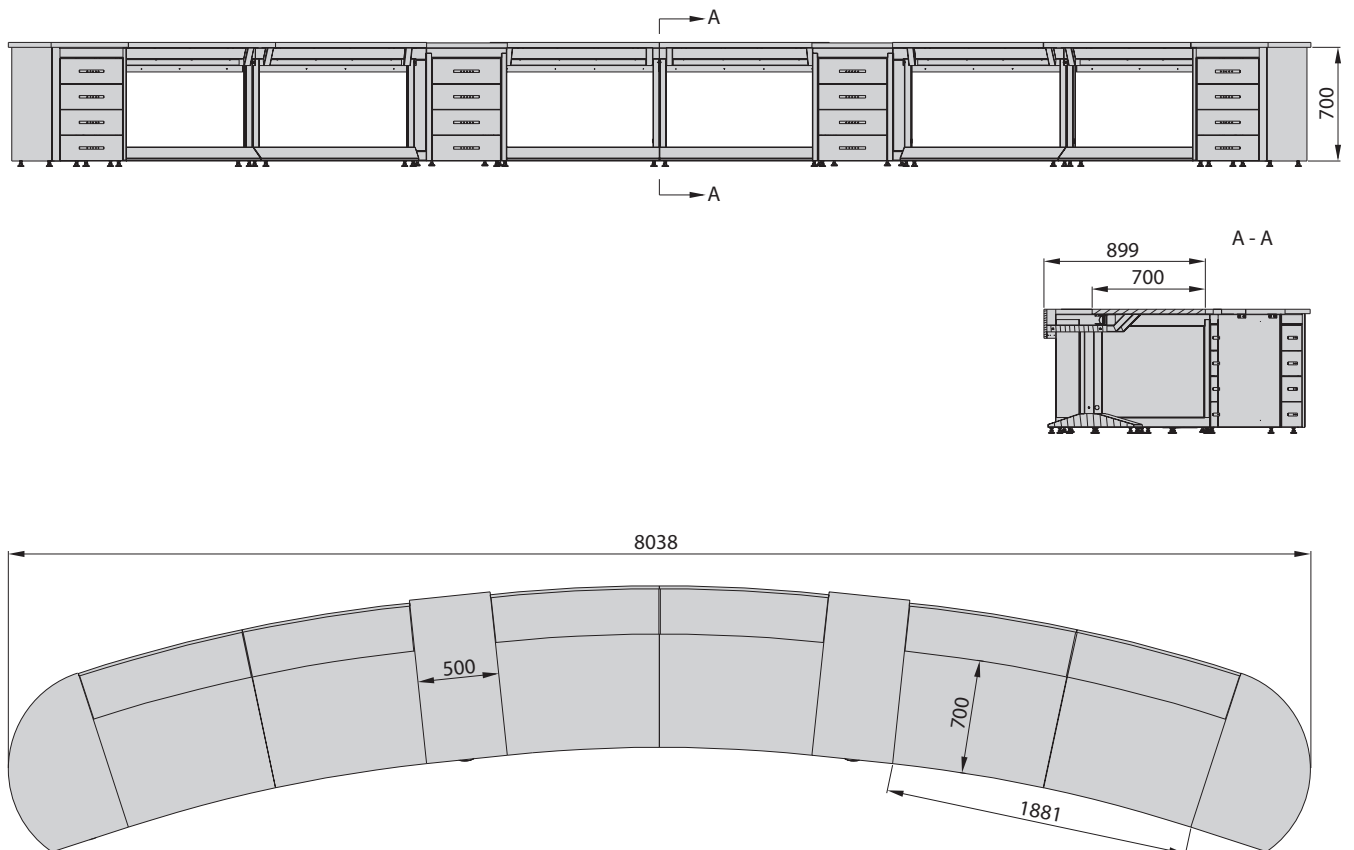

DISPATCH DESKS **PDM Control**

SAMPLE IMPLEMENTATIONS • COMPLETED PROJECTS



## SAMPLE CUSTOMISED PROJECTS

**Single-station desks**

They consist of 19" standard metal cabinets, metal legs or a side element and a top made of MDF board with higher quality and mechanical resistance.

**PDM Classic desk in custom version**

Single-station PDM Classic desk with customer-designed sides. Desk desktop made of Corian.

**Corner PDM Classic desk with furniture cabinet**

Single-station PDM Classic desk consisting of a half-cylinder-shaped side module, two PC modules and a furniture cabinet with drawers. Desktop made of laminated MDF board.

## Desk equipment

Desks can be equipped with monitor brackets, power strips and fan units.



Fans and fan units



Power strips, different versions



Monitor brackets  
- different versions: 1 to 5 monitors can be mounted  
- two types of brackets  
- vertical and horizontal adjustment

## Furniture for dispatch rooms

Office chairs and cabinets made at customer request.



Chairs, different designs and models



Chest of drawers



Printer cabinet



Bookshelf



Clothing wardrobe

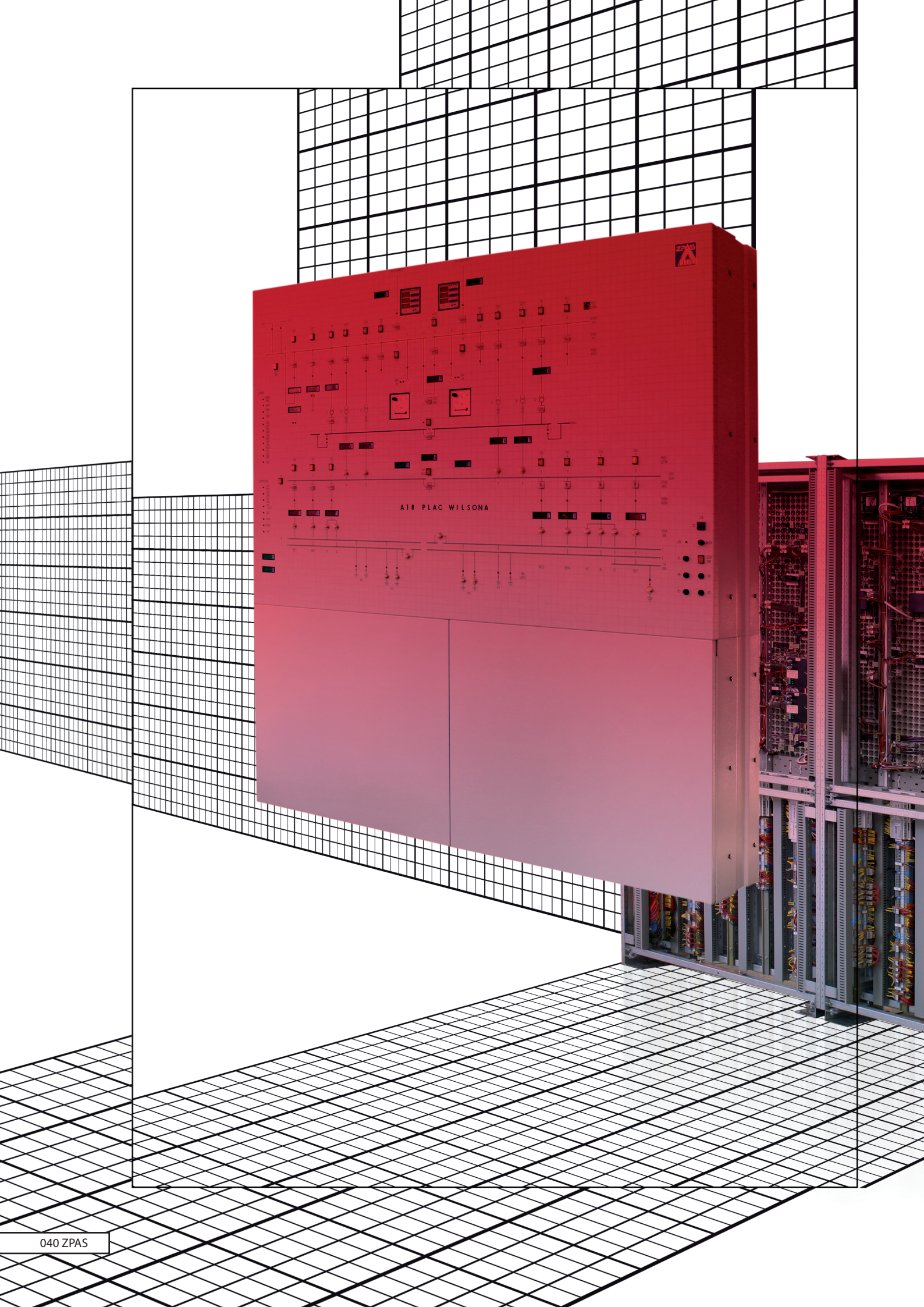

# MIMIC BOARDS

General description of mimic boards .....	42
Design of mimic boards .....	44
Elements of the support structure of free-standing boards .....	45
Matrix elements of mimic boards .....	46
Device assembly .....	48
Front panel colour schemes .....	49
Signal boxes .....	50
Sample realised projects .....	51

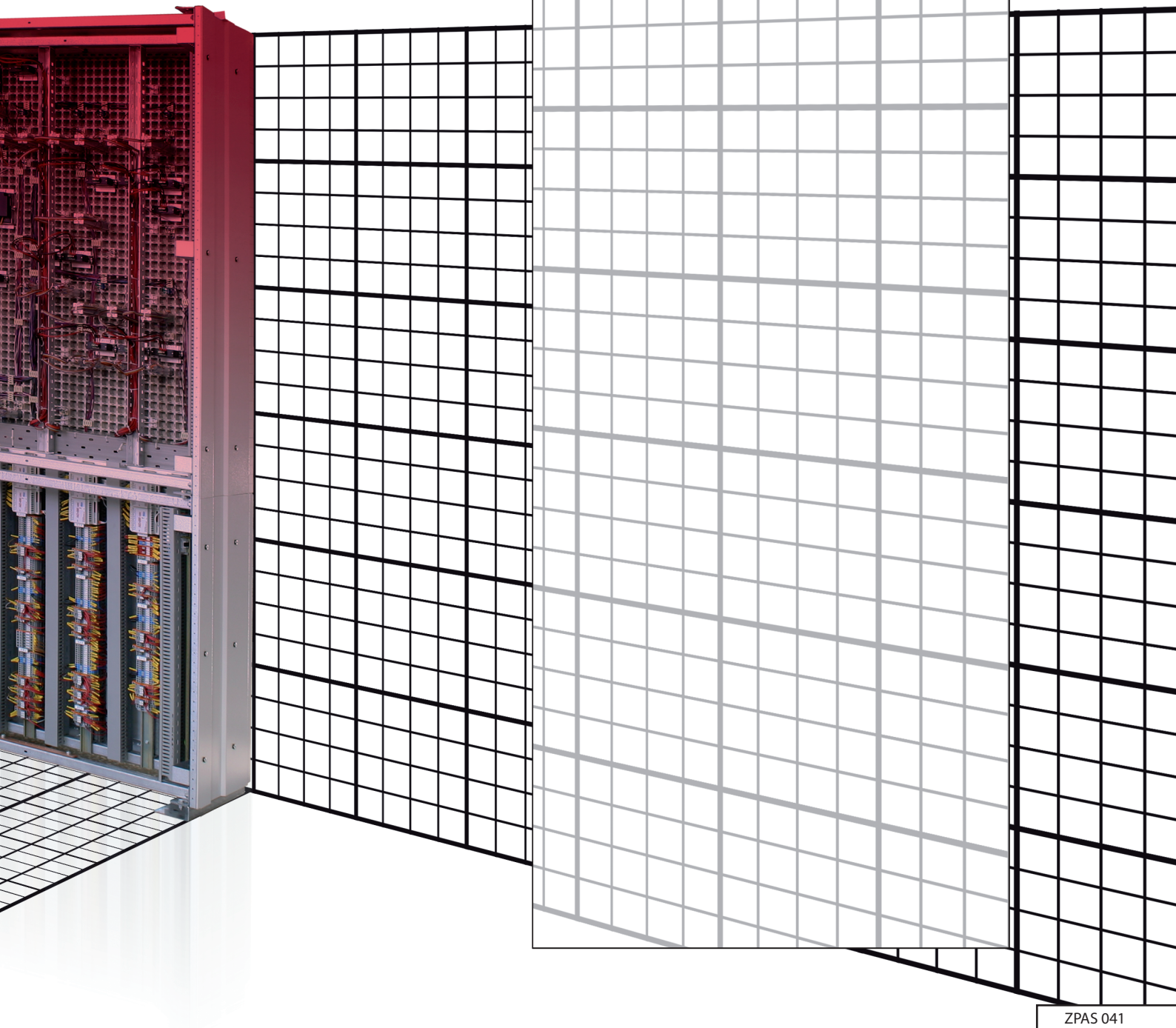

## GENERAL DESCRIPTION OF MIMIC BOARDS

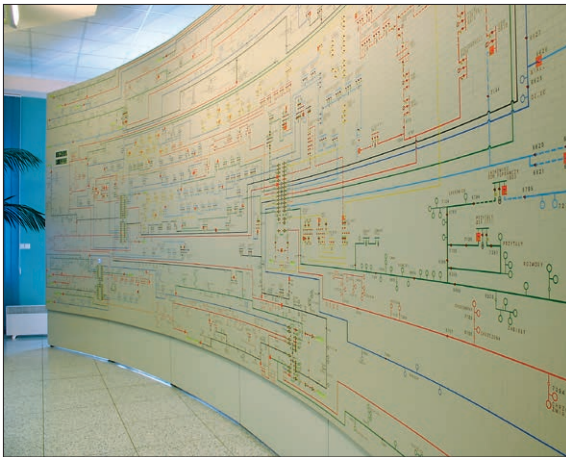
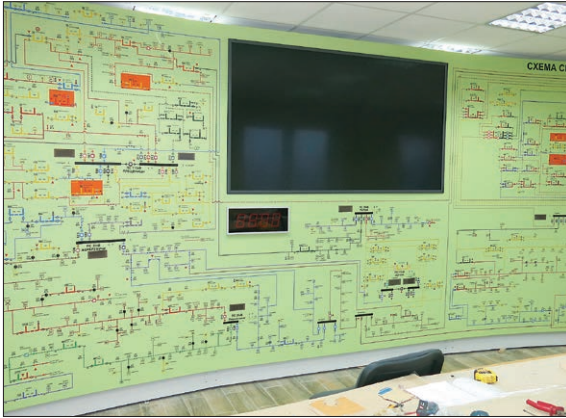

Mimic panels allow to graphically represent technology processes, diagrams of power networks, water supply and distribution network, gas grids, plans and other individually arranged solutions. With the application of modern, complex and automated technologies, mimic boards serve as a visualisation tool effectively supporting control and management processes. Thanks to the use of modules incorporating light components, it is possible to instantly visualise expanding and changing processes and to reflect the operating condition of devices by means of LED signalling with an option of control from front panel devices.

ZPAS is a leading producer of dispatch mimic boards in Poland. Mimic matrix boards are mainly produced for the power sector, for electric power stations, heat and power generation plants, sewage treatment plants, the mining industry, chemical industry, water supply systems, monitoring systems of industrial facilities, etc. Virtually all local and regional power dispatch centres in Poland are equipped with our mimic boards.

Assembly and commissioning of mimic boards at customers' facilities are performed by teams of specialists. Our experts also expand, modernise, develop and modify existing boards. We offer quick and continuous maintenance services. ZPAS keeps abreast of changing market requirements, launching innovative solutions dictated by emerging needs related to the visualisation of power networks and industrial processes.

#### Mimic boards are available in two dimensions:

**DTM** with 24 x 24 mm raster (**preferred system**),

**STM** with 25 x 25 mm raster (older system).

DTM boards are perfectly suited for incorporating analogue indicators without the necessity to use additional covering elements. The basic lighting components of mimic boards are LED modules (with one or many LEDs). There are also other elements fixed in the board's surface, including pushbuttons, switches, controllers, digital displays, analogue and digital meters, signal boxes, analogue and digital clocks, monitors, visual screens, etc. Updating and changing of board images is quick and easy thanks to special caps placed on the frames.

Self-latching caps used in the DTM and STM systems allow for expansion according to individual needs. The matrix surface takes one of four forms: straight, radial (polygonal), broken-type and cabinet-type (wall-mounted). Thanks to specially profiled edges, it is possible to finish boards without visible divisions between individual panels. Cylolac, the material used to make board panel elements, is highly flexible, extremely resistant to temperatures and lightweight. In addition, it has hygiene and fire retardation certificates issued by Polish Scientific Institutes. The material makes it possible to obtain products which are very resistant, flexible and visually attractive. Mimic boards with diagrams are easily adjustable and expandable depending on user needs; flexibility is the main advantage of the design offered. All clean caps can be inserted quickly and easily into any point on the board. Panels with devices and caps can be easily installed in control desks, rotary frames and control cabinet doors.



## DESIGN OF MIMIC BOARDS

### FREE-STANDING BOARDS

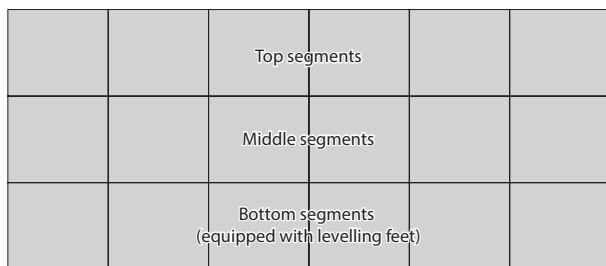

Flat board  
- with evenly aligned segments  
- flat front panel

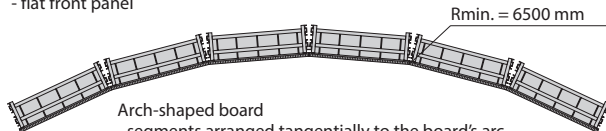

Arch-shaped board  
- segments arranged tangentially to the board's arc  
- front panel profiled according to the board's arc  
- minimum radius of the arc  $R = 6500$  mm

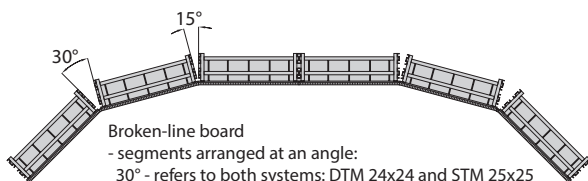

Broken-line board  
- segments arranged at an angle:  
30° - refers to both systems: DTM 24x24 and STM 25x25  
15° - only for STM 25x25 system  
- flat front panels of segments, connected by means of angle connectors

Mimic board in the shape of a triple arm stand

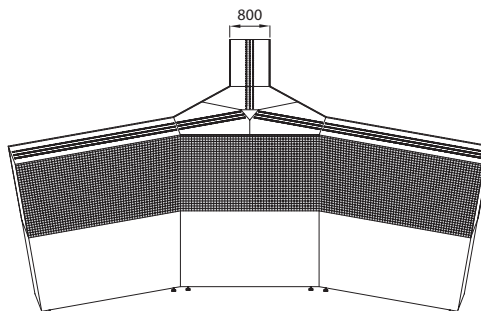

Designed specifically for small control rooms or dispatch centres where, due to inadequate space or for reasons of economy, it is not possible to put up a simple or split structure. The mosaic of the board is mounted on each arm of the star shape. Boards made in this version require at least three operators.

Double-sided board

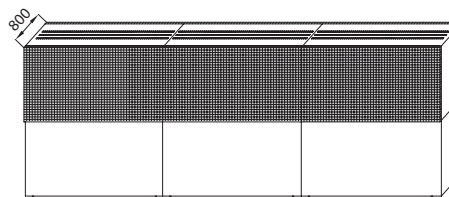

Designed for small control rooms or dispatch centres. The mosaic of the board is mounted on both sides of the structure (in the front and at the back). Boards made in this version require at least three operators.

### WALL-MOUNTED CABINET-TYPE BOARDS

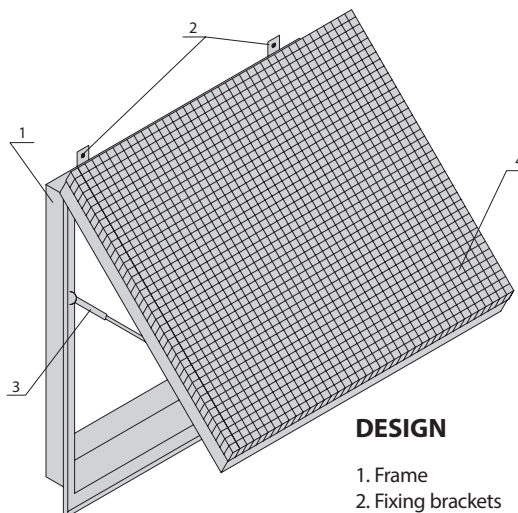
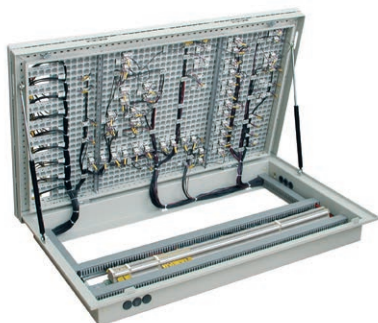

#### DESIGN

1. Frame
2. Fixing brackets
3. Gas shock-absorber
4. Front section with a matrix panel

# ELEMENTS OF THE SUPPORT STRUCTURE OF FREE-STANDING BOARDS

## DESIGN

- 1. Lower frame
- 2. Upper frame
- 3. Angle sections
- 4. Connecting rails
- 5. Front channel section
- 6. Connecting sections
- 7. Mounting brackets
- 8. Truss panel made of plastic frames with 24 mm or 25 mm grid units (material: Cyclocac plastic)
- 9. Aluminium roller shade
- 10. Side cover
- 11. Pins
- 12. Feet

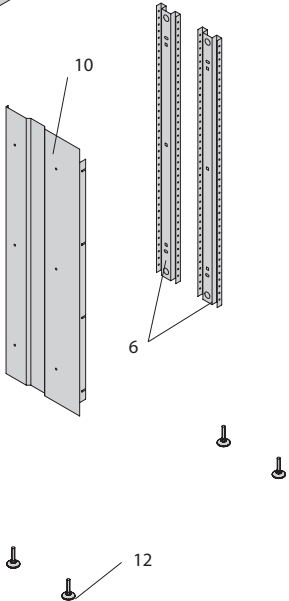
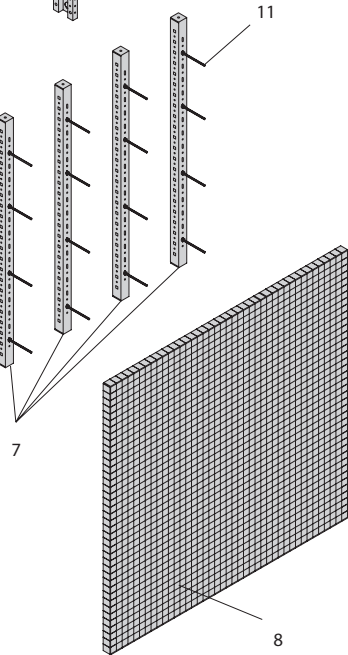
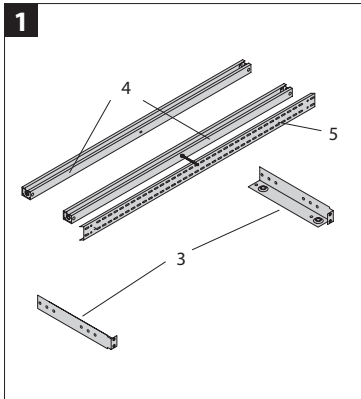
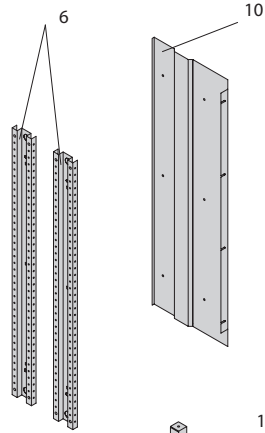
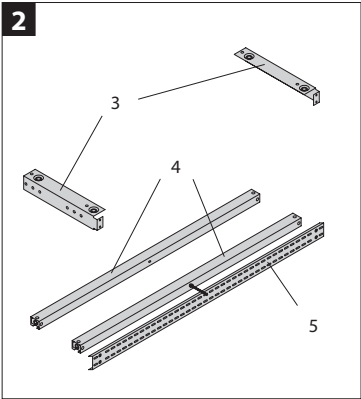
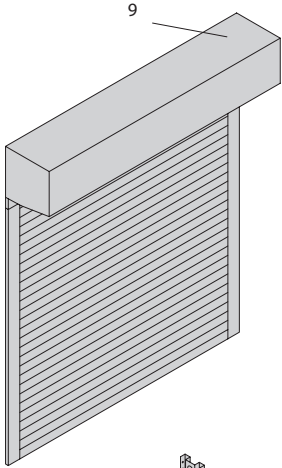
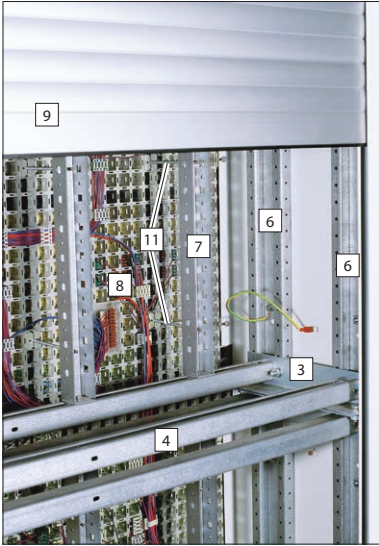
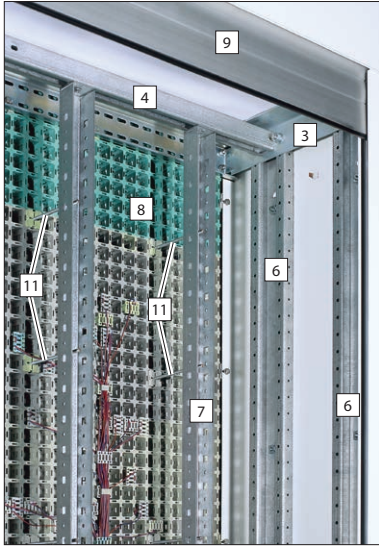

MATRIX ELEMENTS OF MIMIC BOARDS

**Matrix boards are available in two systems:**

- DTM 24 x 24 mm (preferred system), made of M24 and M12 modules
- STM 25 x 25 mm (older system), made of M25 and M12,5 modules

**M24**

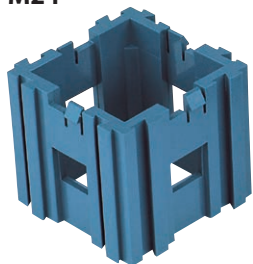

**FRAME**

An element of the self-supporting board structure, forming the central frame of the board's front panel into which caps are inserted.

**M25**

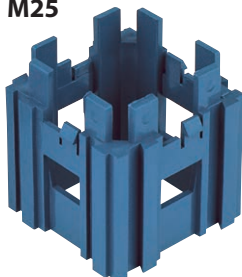

**M12**

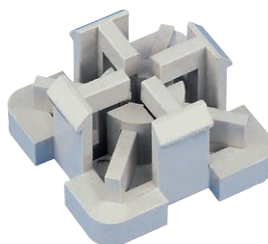

**FIXING CATCH**

Mounted inside the frame, used to fix the board to the support structure.

**M12,5**



**M12**

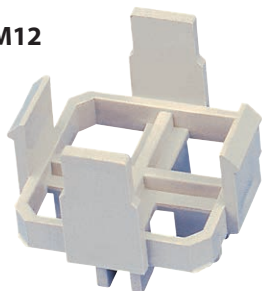

**FRAME EXTENSION**

Mounted inside the frame, designed for cap fixing.

**M12,5**

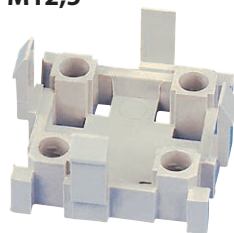

**M24**



**CABLE BUNDLE SUPPORT**

An element cooperating with the clip, protecting conductors extending from the lighting modules in the rear section of the board.

**M25**

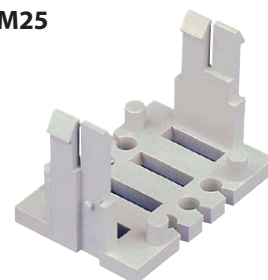

**M24**



**CLIP**

An element used to fix cable bundles on the inside of the front panel. An element cooperating with cable bundle support.

**M25**

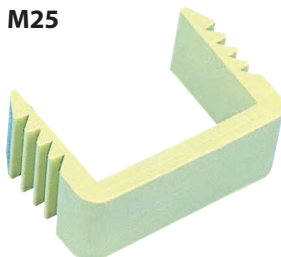

**M24**

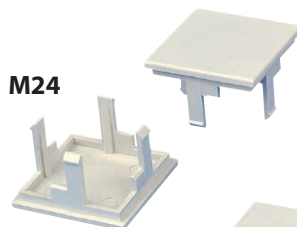

**M25**

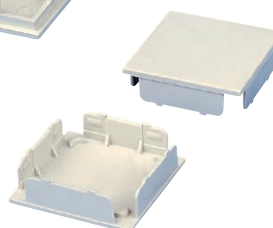

**M12**



**M12,5**



**CAP**

An element forming the front section of the board, featuring matrix elements plotted by screen printing.

## MATRIX ELEMENTS OF MIMIC BOARDS

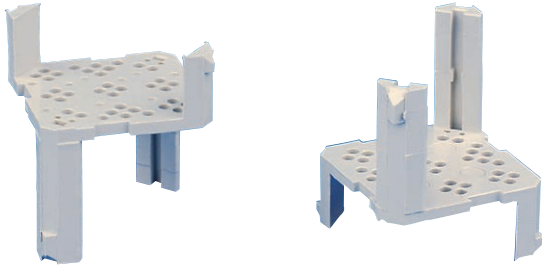
**LED CONNECTOR**

Used to fix LEDs via single-roll strips to the exclusion of PCB.

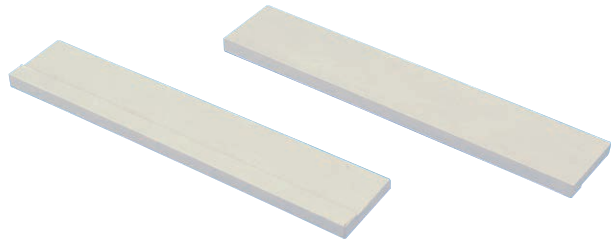
**FRAME**

Used to mount various meters and other devices on the board's front panel.

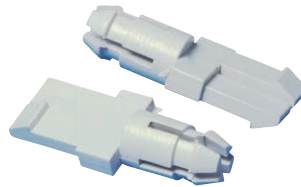
**M24****M25****PCB HOLDER**

An element used to fix the PCB in the frame.

**SIDE COVERING PANEL**

Fixed on the external side walls of the board's frames.

**ILLUMINATED ELEMENTS**

Mounted in caps. Designed for the diffusion of light emitted by LEDs.

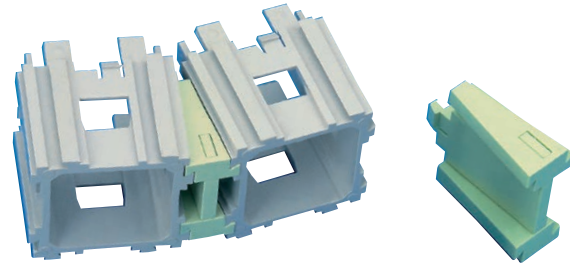
**ANGLE CONNECTOR**

Used for joining elements of the board's front panel at an angle.  
Available in two versions: 15° (on picture) - only for STM system  
30° - for both STM and DTM systems

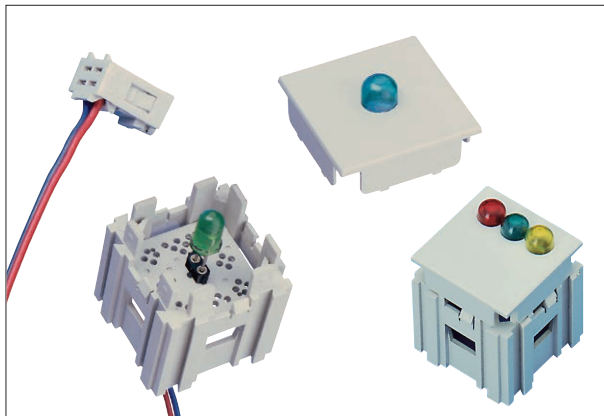

The signalling elements in STM and DTM mimic boards are LEDs. In order to ensure high effectiveness of visualisation, high-luminosity LEDs are used. A variety of LED types and dimensions are employed, depending on particular signalling requirements, e.g. red, green, yellow, blue, single- and multi-colour.

Upon customer request, LEDs are equipped with current-limiting resistors, separation diodes or other matching circuits depending on the type of controller used. Within the matrix, LEDs can be extended to the terminal strips, terminal plates or plates with ends adjusted to a particular controller type.

## DEVICE ASSEMBLY

ZPAS mimic boards offer a possibility of installing meters, indicators, displays, switches, controllers, etc., however in consideration of the fact that customers use a wide variety of different devices, their installation in the mimic boards is always tailored to individual needs and requirements.

Since the majority of devices is designed for assembly on thin front panels made of sheet metal, some devices must be provided with special clamping rings or support brackets (particularly if the weight of a given device may cause front panel deformation).

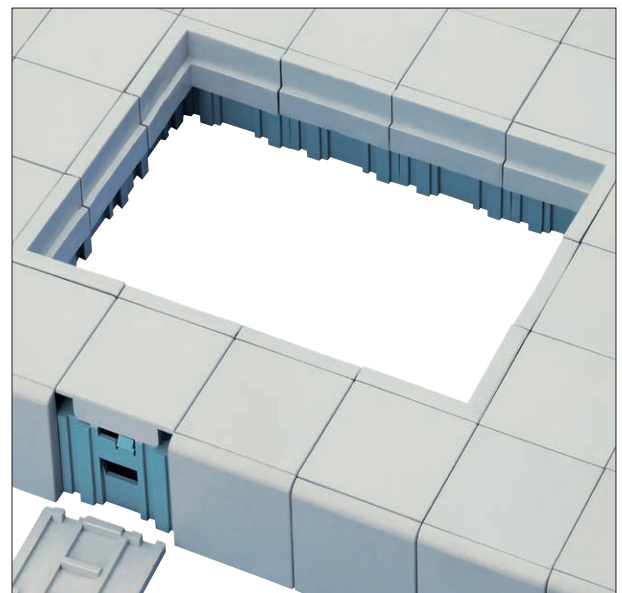
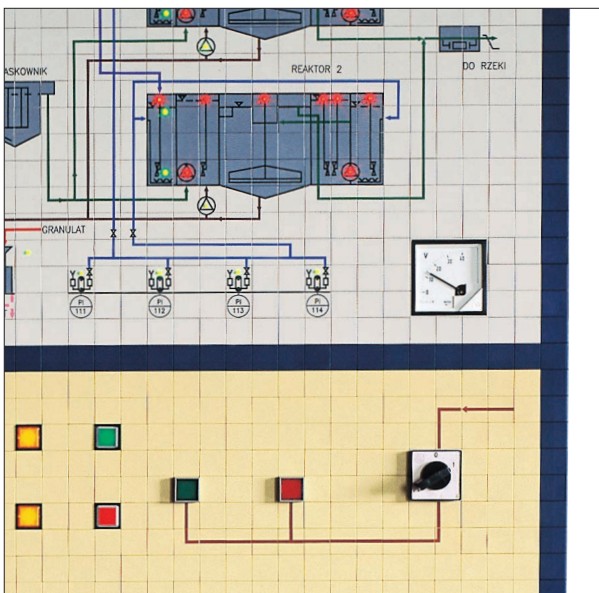
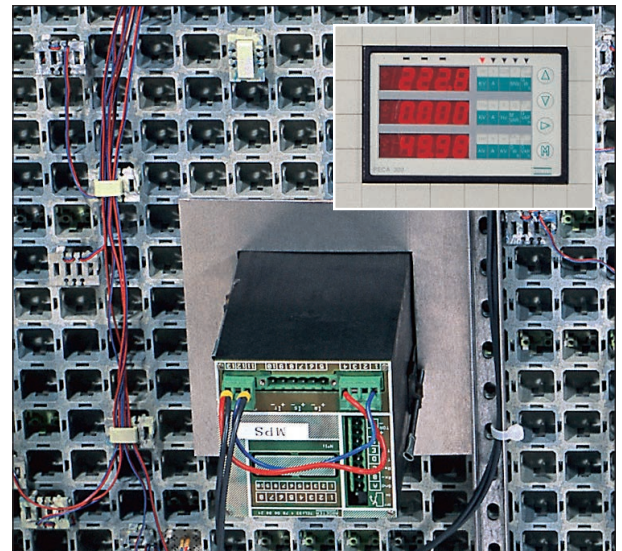

If the dimensions of a device do not correspond to a multiple of the board's module, we offer a range of adaptor elements which allow for construction of a special frame helping to adjust the device to the module. Controllers and switches are usually mounted by means of adaptor plates with front sections covered with the same surface patterns as the front sections of the boards. Details concerning installation methods are individually agreed with the customer.

# FRONT PANEL COLOUR SCHEMES

**NOTE:**  
The background colour of the board can be freely selected, however on account of proven ergonomic properties, the following colours are recommended:

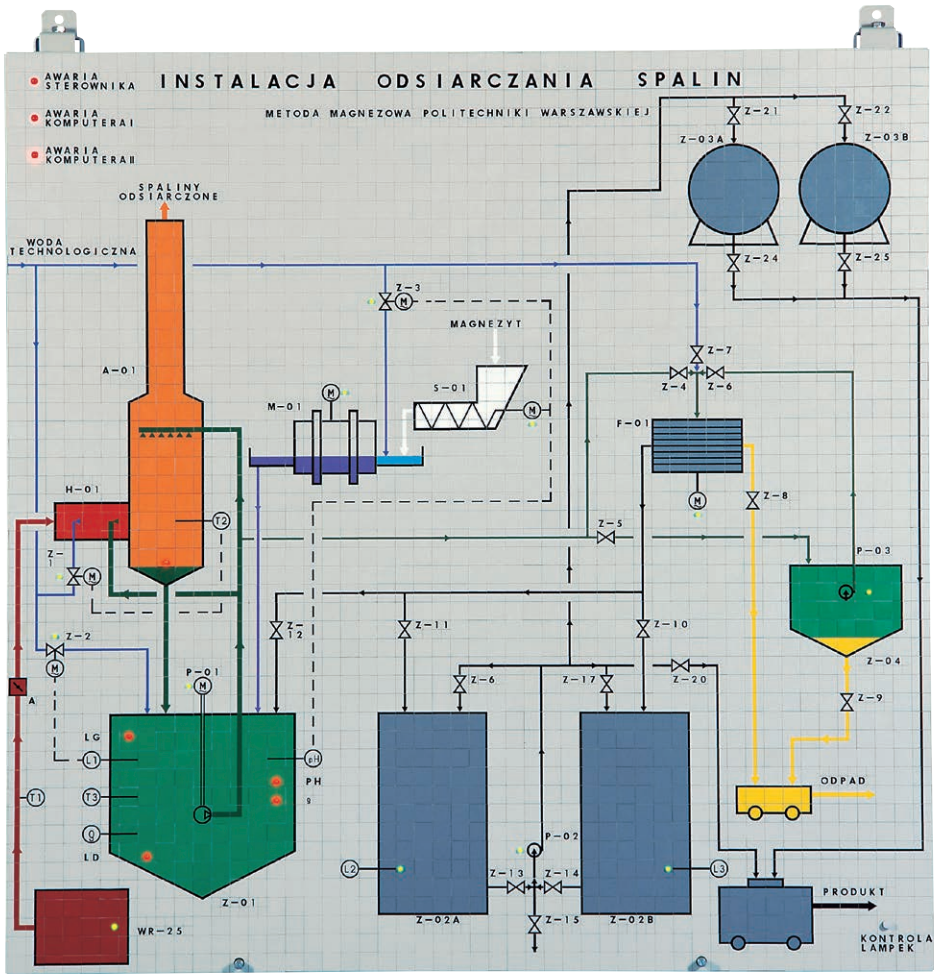
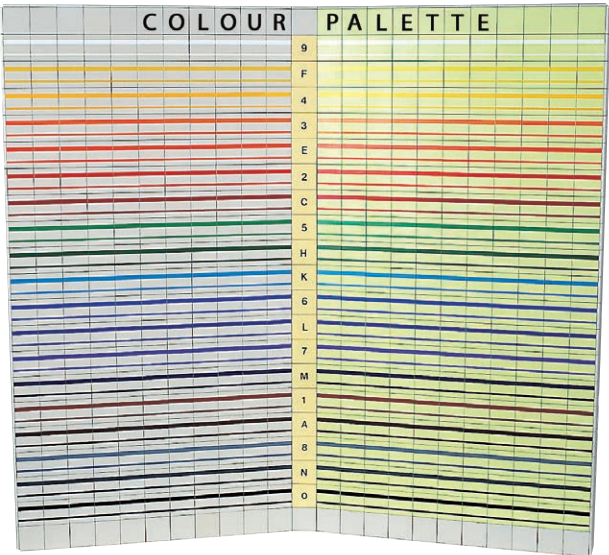
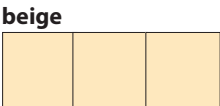
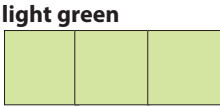
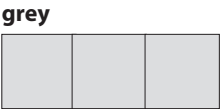

KSD SIGNAL BOXES



KSD-type signal boxes are designed for signalling status of the facility. They are mounted in matrix frames; caps of the signal boxes are flushed with the surface of the front panels of STM boards and control desks. Sets of signal boxes enclosed in aluminium frames can also be fixed in metal, wood-like or other plates (e.g. cabinets, desktops and top segments).

**Note:** KSD signal boxes can only be used in the STM system with 25 x 25 mm raster.

**TECHNICAL DATA**

- Control voltage ..... 18-24 V DC
- Power consumption..... ca. 80 mA
- Colour of illumination ..... red, green, yellow
- Dimensions ..... 50.3 x 25.15 mm
- Outlets ..... rack and panel connector, terminal strip or other types, based on individual arrangements

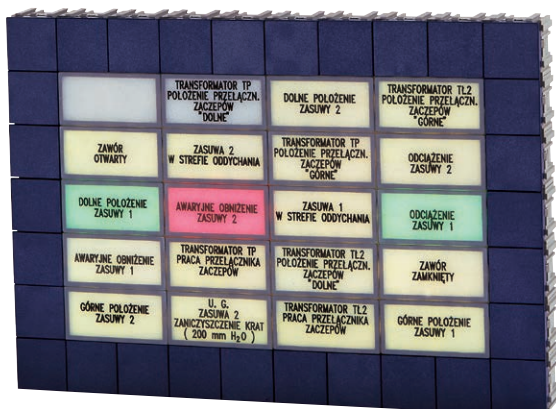

**DESIGN**

Each box incorporates three basic elements: a main body, a LED plate and a cap (non-transparent white). The surface of the cap has an inscription, sign or symbol plotted by screen printing or engraved. Another possibility is the use of transparent caps with inscriptions made on mat film or tracing paper placed underneath. Signal boxes are made as single units or in multiple sets in any configuration.

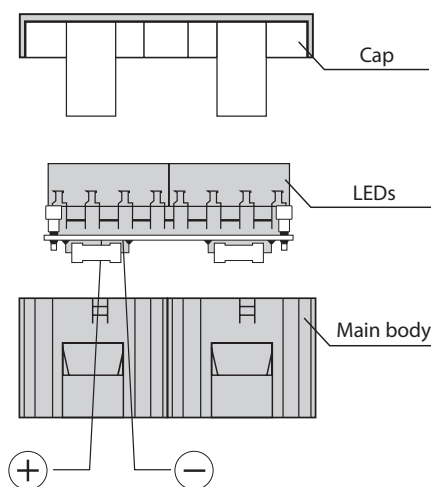
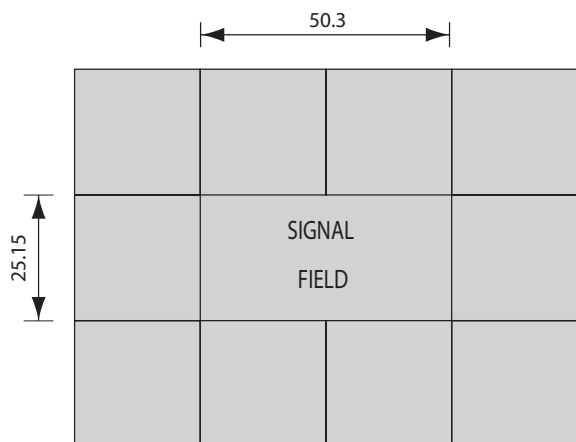

SAMPLE REALISED PROJECTS



SAMPLE REALISED PROJECTS



SAMPLE REALISED PROJECTS

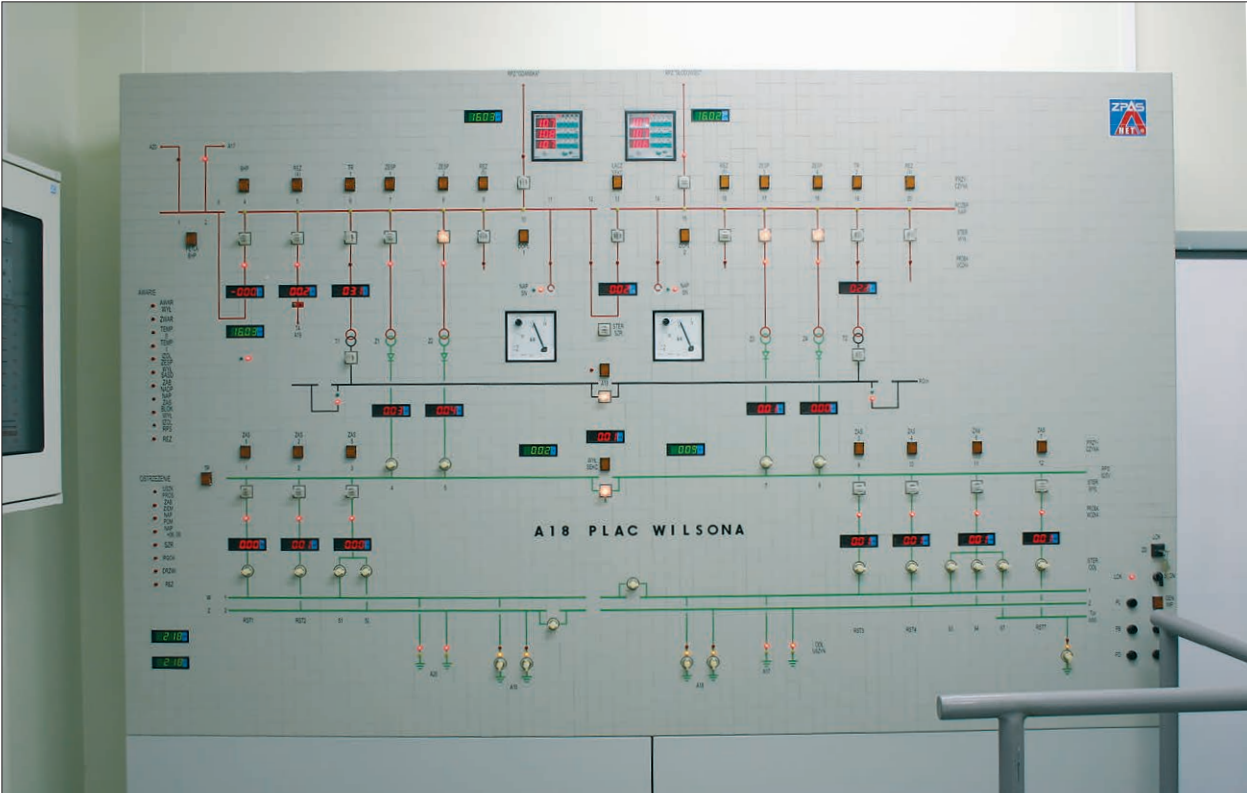
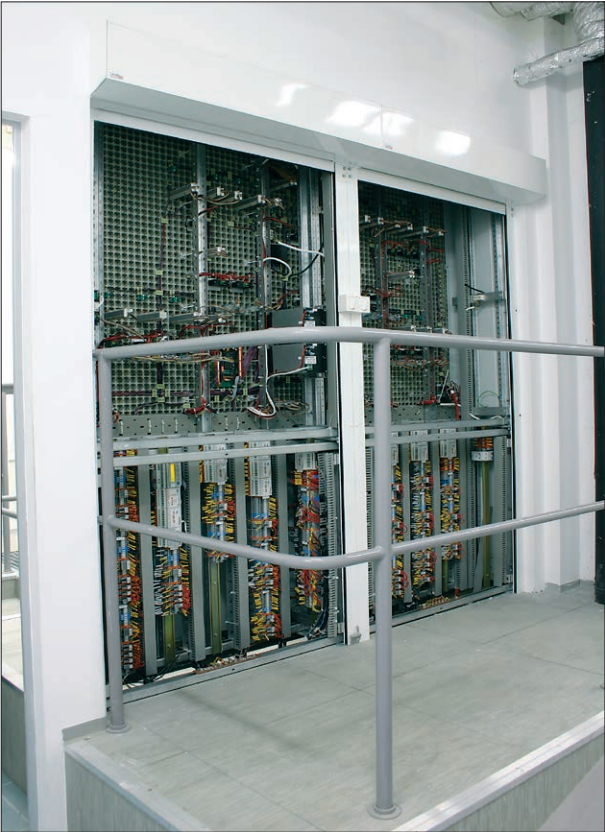

SAMPLE REALISED PROJECTS

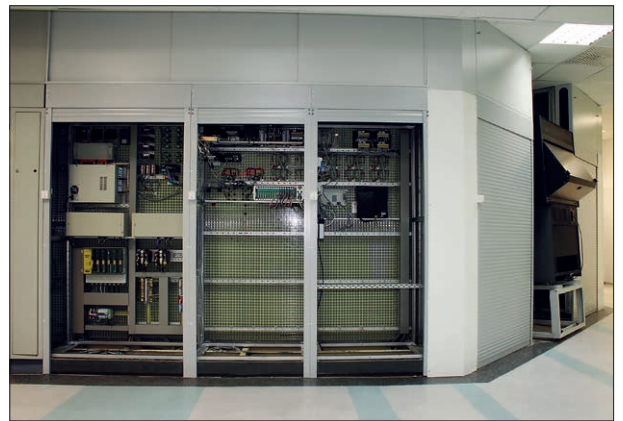

SAMPLE REALISED PROJECTS



SAMPLE REALISED PROJECTS

MATRIX BOARDS IN ALUMINIUM FRAMES

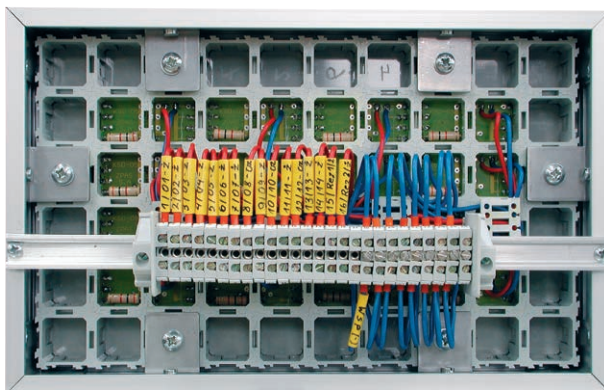

Signalling box designed for mounting in the control desk

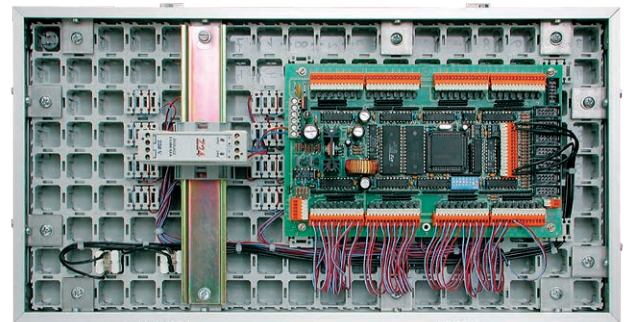

Monitoring of climatic conditions in a server room, based on the ZPAS Control Overseer system. The system records relevant data via LAN, communicates emergency conditions by short text messages and makes it possible to visualise the facility on a computer screen and mimic board.

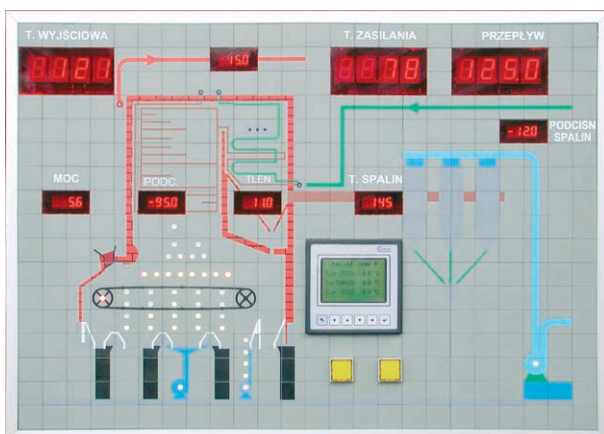

Control and monitoring of operations of an industrial facility

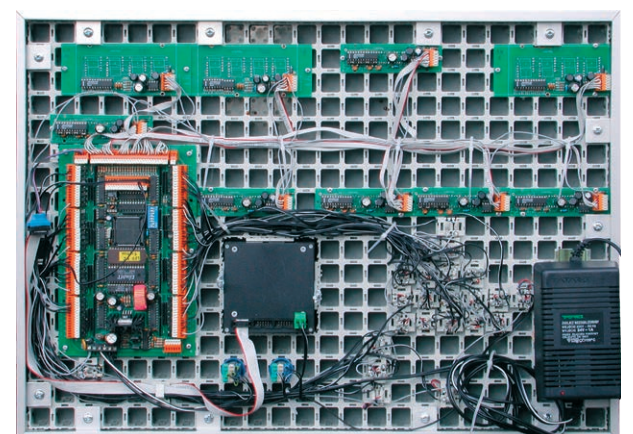

SAMPLE REALISED PROJECTS

MATRIX BOARDS IN ALUMINIUM FRAMES

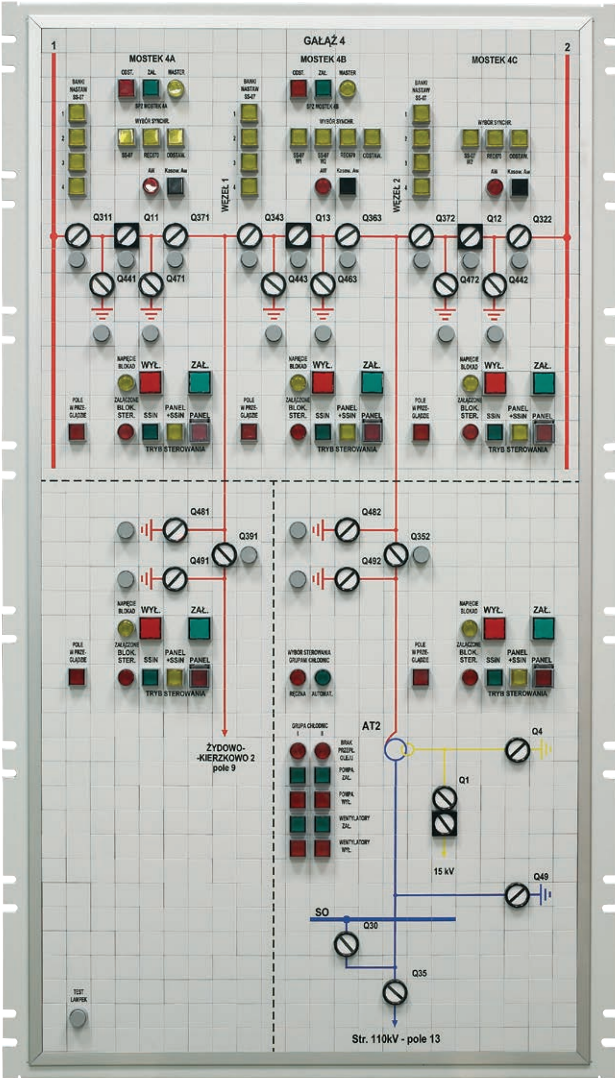
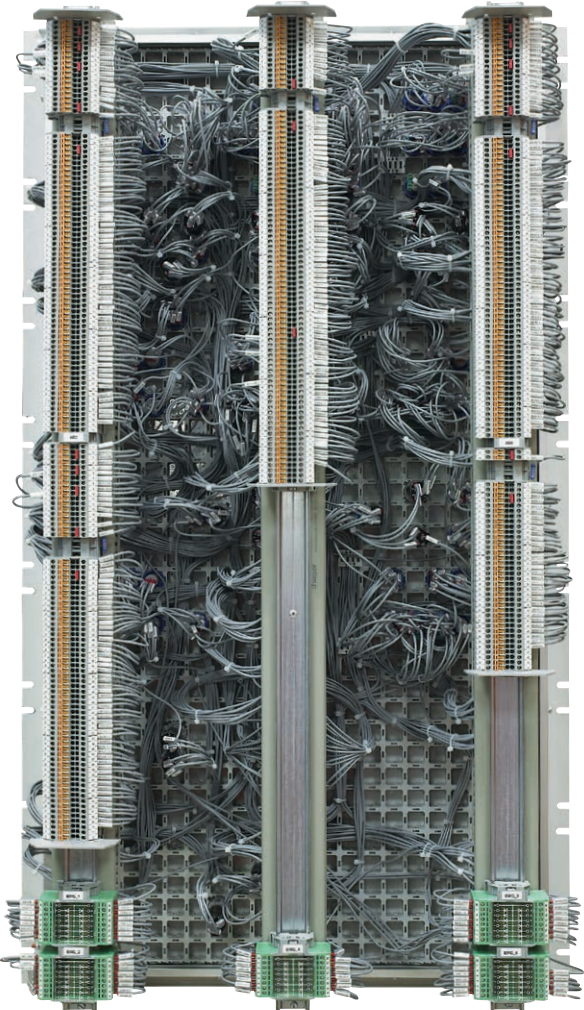

Matrix board in an aluminium frame set in a masking panel for mounting in a control cabinet swing frame for a grid station. The board has a fragment of the electrical diagram with backlit buttons, electromagnetic indicators and LED modules, with connections to terminal strips.



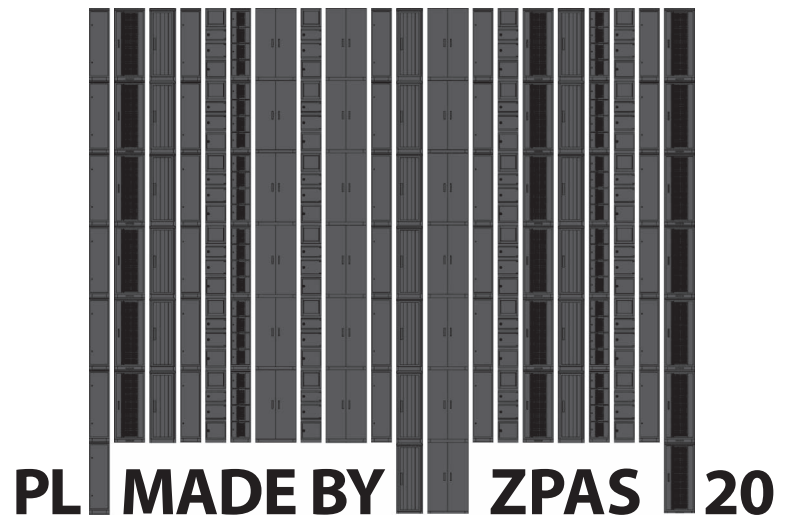

Catalogue of ZPAS Group Products

**Solutions for Control Rooms**

Edition: 01.2020 EN

**Published by:**

ZPAS S.A., Przygórze 209, 57-431 Wolibórz, Poland

We reserve the right to modernise and modify our products.  
Technical modifications shall not affect product functionality.  
Misprints and errors of content that may be found in this  
catalogue may not be used as a basis for complaints.



**ZPAS**

01.2020 EN

**ZPAS S.A.**

PRZYGÓRZE 209 · 57-431 WOLIBÓRZ · POLAND

PHONE: +48 74 872 01 00 · FAX: +48 74 872 40 74

**INFO@ZPAS.PL · WWW.ZPAS.PL**